

# Power Factor Correction Fed DC Motor with Bridgeless SEPIC Converter

Gantaiah Swamy<sup>1</sup> | M.Aravind Kumar<sup>2</sup> | N.Abhi Ram<sup>3</sup>

<sup>1</sup>Assistant Professor, Department of EEE, Andhra Loyola Institute of Engineering & Technology, Vijayawada, Andhra Pradesh, India.

<sup>2,3</sup>Department of EEE, Andhra Loyola Institute of Engineering & Technology, Vijayawada, Andhra Pradesh, India.

## To Cite this Article

Gantaiah Swamy, M.Aravind Kumar and N.Abhi Ram, "Power Factor Correction Fed DC Motor with Bridgeless SEPIC Converter", *International Journal for Modern Trends in Science and Technology*, Vol. 03, Special Issue 02, 2017, pp. 01-04.

## ABSTRACT

*In this project, the Single Ended Primary Inductor converter (sepic) is used to achieve high power factor with reduce input ripple current. The power factor correction is suffered from high conduction loss due to input bridge diode. The bridgeless sepic converter is used to avoid conduction loss. The input current ripple is reduced by using an additional winding and an auxiliary capacitor. In switching period, the input current is proportional to the input voltage and achieved near unity power.*

**KEYWORDS:** Power Factor Correction, DC-DC Converter, Sepic Converter, Bridgeless Sepic Converter.

Copyright © 2017 International Journal for Modern Trends in Science and Technology  
All rights reserved.

## I. INTRODUCTION

The power factor of an AC electric power system is defined as the ratio of the real power flowing to the load to the apparent power in the circuit, and is a dimensionless number between 0 and 1. Real power is the capacity of the circuit for performing work in a particular time. Apparent power is the product of the current and voltage of the circuit. Due to energy stored in the load and returned to the source, or due to a non-linear load that distorts the wave shape of the current drawn from the source, the apparent power will be greater than the real power. In an electric power system, a load with a low power factor draws more current than a load with a high power factor for the same amount of useful power transferred. Because of the costs of larger equipment and wasted energy, electrical utilities will usually charge a higher cost to industrial or commercial customers where there is

a low power factor. Linear loads with low power factor (such as induction motors) can be corrected with a passive network of capacitors or inductors. Non-linear loads, such as rectifiers, distort the current drawn from the system.

In such cases, active or passive power factor correction may be used to counteract the distortion and raise the power factor. The devices for correction of the power factor may be at a central substation, spread out over a distribution system, or built into power-consuming equipment. Electronic switch-mode DC to DC converters are available to convert one DC voltage level to another.

## II. CIRCUIT DIAGRAM OF BRIDGELESS SEPIC CONVERTER

This topology is similar to the bridgeless boost PFC rectifier. Despite the mentioned advantage, in comparison to the conventional

SEPIC rectifier, this converter has three extra passive

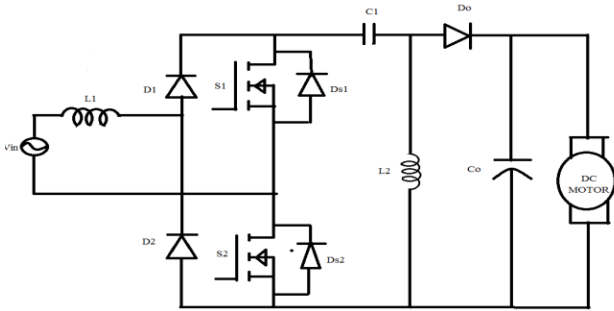

elements which contribute to the volume and weight of the converter. Another major problem with this converter is that it doubles the output voltage which considerably increases the size of output filter. To overcome these limitations, a new bridgeless SEPIC PFC is introduced in this paper. This converter has no extra (passive or active) elements in comparison to conventional SEPIC PFC.

Also, in this converter, the conduction losses (number of active elements in the current path) are reduced in comparison to the conventional SEPIC PFC. The bridgeless Sepic Rectifier is shown in above figure.

In this converter, The component count is reduced and it shows high efficiency due to the absence of the full-bridge diode. However, in this converter, an input inductor with large inductance should be used in order to reduce the input current ripple. In addition, the conduction losses on intrinsic body diodes of the switches are caused by using single pulse width modulation (PWM) gate signal. In order to overcome these problems, a bridgeless SEPIC converter is changed in proposed.

### III. DESIGNED BRIDGELESS SEPIC CONVERTER

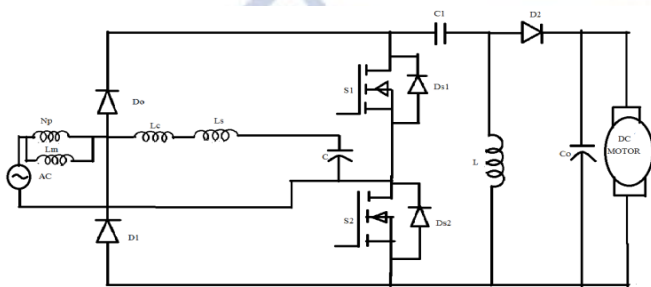

The component count is reduced and it shows high efficiency due to the absence of the full-bridge diode. However, in this converter, an input inductor with large inductance should be

used in order to reduce the input current ripple. In addition, the conduction losses on intrinsic body diodes of the switches are caused by using single pulse width modulation (PWM) gate signal. In order to overcome these problems, a bridgeless SEPIC converter is changed in proposed. It is shown in figure. An auxiliary circuit, which consists of an additional winding of the input inductor, an auxiliary small  $l$  inductor, and a capacitor, is utilized to reduce the input current ripple. Coupled inductors are often used to reduce current ripple. The operation of the proposed converter is symmetrical in two half-line cycles of input voltage. Therefore, the converter operation is analyzed during one switching period in the positive half-line cycle of the input voltage. It is assumed that the converter operates in discontinuous conduction mode (DCM), so the output diode  $D_o$  is turned OFF before the main switch is turned ON.

### IV. DESIGNED CIRCUIT ANALYSATION

The auxiliary circuit includes additional winding  $N_s$  of the input inductor  $L_c$ , an auxiliary inductor  $L_s$ , and a capacitor  $C$ . The coupled inductor  $L_c$  is modelled as a magnetizing inductance  $L_m$  and an ideal transformer which has a turn ratio of  $1:n$  ( $n=N_s/N_p$ ). The leakage inductance of the coupled inductor  $L_c$  is included in the auxiliary inductor  $L_s$ . The other components  $C_1$ ,  $L_1$ ,  $D_o$ , and  $C_o$  are similar to those of the conventional SEPIC PFC converter. Diodes  $D_1$  and  $D_2$  are the input rectifiers and operate like a conventional SEPIC PFC converter.  $D_{s1}$  and  $D_{s2}$  are the intrinsic body diodes of the switches  $S_1$  and  $S_2$ . The switches  $S_1$  and  $S_2$  are operated with the proposed gate signals.

#### Mode 1 Operation:

At  $t_0$ , the switch  $S_1$  is turned ON and the switch  $S_2$  is still conducting. Since the voltage  $v_p$  across  $L_m$  is  $V_{in}$ , the magnetizing current  $i_m$  increases from its minimum value  $I_{m2}$  linearly with a slope of  $V_{in}/L_m$ .

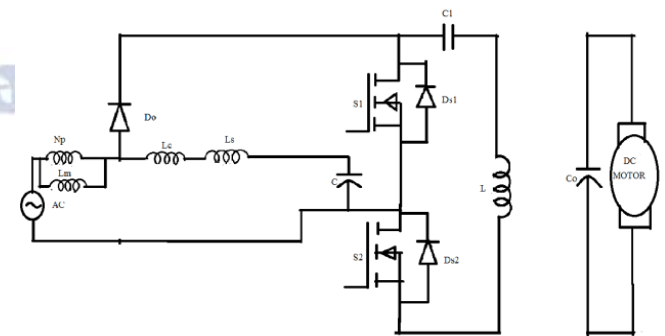

Mode 1 operation

**Mode 2 Operation :**

At  $t_1$ , the switch S1 is turned ON and the switch S2 is still conducting. Since the voltage  $v_p$  across  $L_m$  is  $-V_o$ , the magnetizing current  $i_m$  decreases from its maximum value  $i_{m1}$  linearly with a slope of  $-V_o / L_m$ . It is shown in below figure.

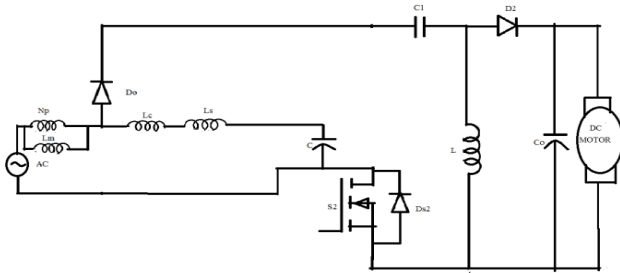

**Mode 2 Operation**

**Mode 3 Operation :**

At  $t_2$ , the current  $i_{D_o}$  becomes zero, and the diode  $D_o$  is turned OFF. Since  $\dot{i}_n = i_m - i_{D_o} = -i_s - \dot{L}_1$  in this mode, the input current  $i_n$  is the sum of freewheeling currents  $i_{s2}$  and  $i_{L2}$ . It is shown in below figure.

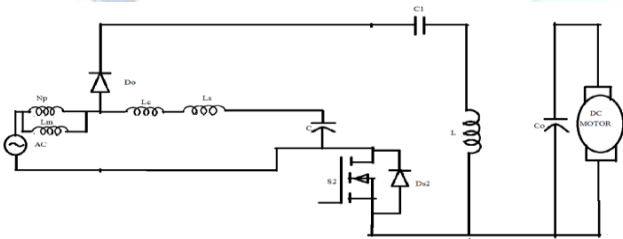

**Mode 3 Operation**

**V. SIMULATION OVERVIEW**

In industry, MATLAB is the tool of choice for high productivity research, development, and analysis. MATLAB features a family of add-on application-specific solutions called toolboxes. Very important to most users of MATLAB, toolboxes allow you to learn and apply specialized technology. Toolboxes are comprehensive collections of MATLAB functions (Mfiles) that extend the MATLAB environment to solve particular classes of problems. Areas in which toolboxes are available include signal processing, control systems, neural networks, fuzzy logic, wavelets, simulation, and many others.

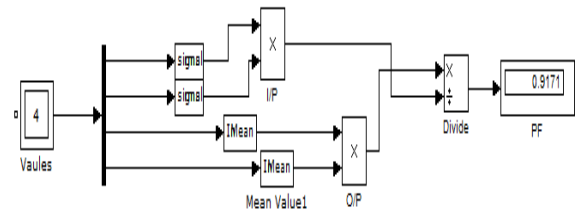
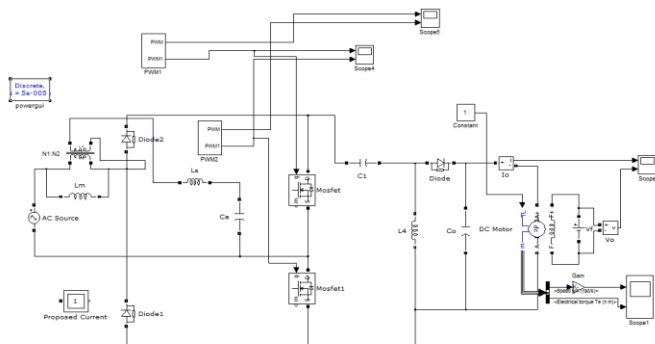

Sim Power Systems libraries contain models of typical power equipment such as transformers, lines, machines, and power electronics. These models are proven ones coming from textbooks, and their validity is based on the experience of the Power Systems Testing and Simulation Laboratory of Hydro-Québec, a large North American utility located in Canada, and also on the experience of École de Technologie Supérieure and Université Level. The capabilities of SimPower Systems software for modeling a typical electrical system are illustrated in demonstration files.

The main powerlib library window also contains the Powergui block that opens a graphical user interface for the steady-state analysis of electrical circuits.

**VI. SIMULATION RESULTS**

In this proposed system, we get 0.91 power factor. The efficiency and power factor between conventional Sepic Converter and proposed sepic converter is shown in below figure.

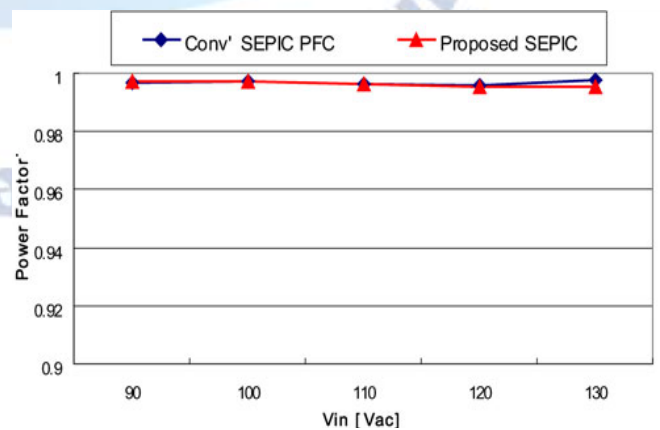
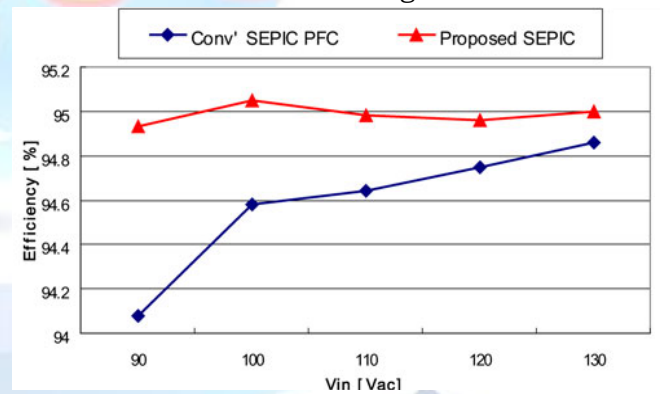

The wave forms of input ripples

The output current and output voltage wave forms

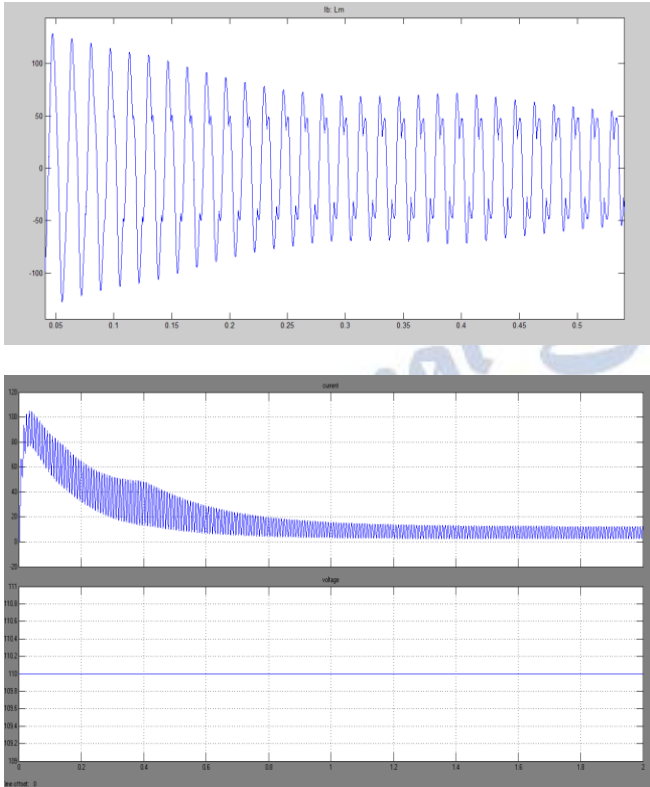

### VII. CONCLUSION

A bridgeless SEPIC converter with ripple-free input current has been proposed. In order to improve the efficiency, the input full-bridge diode is eliminated. The input current ripple of the proposed converter is significantly reduced by utilizing an auxiliary circuit, consisting of an additional winding of the input inductor, an auxiliary small inductor, and a capacitor. The theoretical analysis, simulation results, and experimental results were provided.

### REFERENCES

- [1] Govindaraj Thangavel, Debashis Chatterjee, and Ashoke K. Ganguli, "FEA Simulation Models based Development and Control of An Axial Flux PMLM," International Journal of Modelling and Simulation of Systems, Vol.1, Iss.1, pp.74-80, 2010
- [2] Govindaraj Thangavel, Debashis Chatterjee, and Ashoke K. Ganguli, "Design, Development and Control of an Axial Flux Permanent Magnet Linear Oscillating Motor using FE Magnetic Analysis Simulation Models," Int. Journal of Electrical and Electronics Engineering, Oradea, Romania, October 2010