



# Multi-Mode Power Converter for PV based Electric Vehicle Station

M Madhava Rao<sup>1</sup>, Dr. K Padma<sup>2</sup>

<sup>1</sup>PG Scholar, Dept of Electrical Engineering, Andhra University, Andhra Pradesh, India

<sup>2</sup>Associate Professor, Dept of Electrical Engineering, Andhra University, Andhra Pradesh, India

## To Cite this Article

M Madhava Rao and Dr. K Padma. Multi-Mode Power Converter for PV based Electric Vehicle Station. International Journal for Modern Trends in Science and Technology 2023, 9(07), pages. 01-05. <https://doi.org/10.46501/IJMTST0908001>

## Article Info

Received: 02 July 2023; Accepted: 23 July 2023; Published: 29 July 2023.

**Copyright** © 2023 M Madhava Rao et al. This is an open access article distributed under the [Creative Commons Attribution License](#), which permits unrestricted use, distribution, and reproduction in any medium, provided the original work is properly cited.

## ABSTRACT

*As an environmentally friendly vehicle, the increasing number of electrical vehicles (EVs) leads to a pressing need of widely distributed charging stations, especially due to the limited on-board battery capacity. However, fast charging stations, especially super-fast charging stations may stress power grid with potential overload at peaking time, sudden power gap and voltage sag. This project discusses the detailed modelling of a multiport converter-based EV charging station integrated with DC power generation, and battery energy storage system. This project analyses the capability for Plug-in electric vehicles (PEVs) in Vehicle to Home (V2H) scenarios, for which the vehicle acts as a residential battery storage system and/or a backup generator during a grid outage or more frequent short duration distribution system fault. The simulation and experimental results show that PCMM can meet the design target and verify the feasibility of the model. This charger has been implemented using a simulation analysis with a space vector modulation technique to validate its operation. The simulation results obtained foresee an adequate interaction between the proposed charger and a compatible autonomous EMS in a typical residential setting.*

## 1. INTRODUCTION

With the rapid growth and challenges of power generation, distribution, and usages, renewable energy technologies can play an important role in future power supply due to increased awareness of environmental pollution. In the case of power supply system to remote and isolated communities, a renewable energy based stand-alone power system can be a particularly attractive cost-effective solution, as grid extension is often impractical due to economic and technical constraints.

Generation with EV charging infrastructure; however, the PV integration is still considered as a minor portion

of power source for EV charging stations in researches. As for the higher demand of fast-speed charging during daytime, the rapid development of PV generation optimizes power consumption at peak hours with its adequate daytime generations. With respect to the intermittency of solar energy, a battery energy storage (BES) can be employed to regulate the DC bus or load voltage, balance power gap, and smooth PV power. Considering the high power density and high efficiency merits of the multi port power converters, a multi-port DC/DC converter is employed in this paper for the EV charging station instead of using three separate DC/DC converters

Among the aforementioned research, the charging station architectures can be classified into two topologies: using AC bus or DC bus. As PV output and BES can both be regarded as DC current source, DC bus charging station is chosen here to improve the utilization efficiency of solar energy and decrease the cost and losses of converters. Compared with isolated multi port converters, non-isolated multi port converters that are usually derived from buck or boost converters may feature a more compact design, higher power density, and higher efficiency compared with isolated multi port converters.

## 2. ELECTRIC VEHICLES

A typical electric vehicle (EV) has a battery pack connected to an electric motor and provides traction power through the use of a transmission. The batteries are charged primarily by a battery charger that receives its power from an external source such as the electrical utility. Also during regenerative braking, the motor acts as a generator which provides power back to the batteries and in the process slows down the vehicle. The primary advantage of an EV is that the design is simple and has a low part count. The primary disadvantage is that the driving range of the vehicle is limited to the size of the battery and the time to re-charge the battery can be from 15 minutes to 8 hours depending on how far the vehicle was last driven, the battery type and battery charging method.

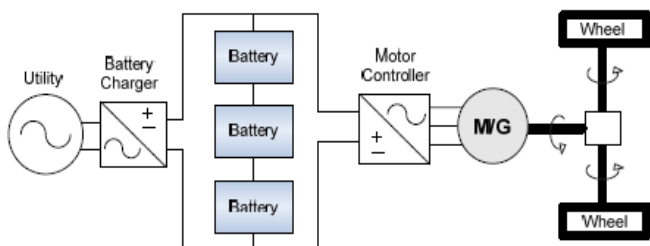

Figure 1: Typical EV configuration

### Plug-In Vehicles:

According to the Electric Power Research Institute (EPRI), more than 40% of U.S. generating capacity operates overnight at a reduced load overnight, and it is during these off-peak hours that most PHEVs could be recharged. Recent studies show that if PHEVs replace one-half of all vehicles on the road by 2050, only an 8% increase in electricity generation (4% increase in capacity) will be required [2]. Most of the electric

vehicles that are of plug-in type, utilize on-board battery chargers to recharge the batteries using utility power. The simplest form of a plug-in electric vehicle is shown in Fig. 1. This configuration consists of a battery system and a motor controller that provides power to the motor, which in-turn supplies power to the wheels for traction. Many of today's EVs use a permanent magnet electric motor that can also act as a generator to recharge the batteries when the brakes are applied. During regenerative braking, the motor acts as a generator that provides power back to the batteries and in the process slows down the vehicle. Friction brakes are used when the vehicle must be stopped quickly or if the batteries are at full charge.

The components that make up a typical HEV include a battery pack, motor controller, motor/generator, internal combustion engine, transmission and driveline components. The primary power electronics include a DC-AC motor controller which provides three-phase power to a permanent magnet motor. The Toyota Prius HEV configuration is given in Fig. 2. The Prius design uses two permanent magnet motors/generator, one of 10kW and the other of 50kW. The battery is connected to a booster and inverter before feeding to the motor/generators. The power electronics are bidirectional and used for both charging the battery and powering the motors. The motor/generators and gasoline engine feed into a planetary gear set. The system operates in a continuously variable transmission (CVT) mode where the gear ratio is determined by the power transfer between the battery, motor/generators and gasoline engine [3], [4]. The batteries can also be charged using regenerative braking of the large motor/generators. There is no provision to charge the batteries externally. For plug-in hybrid electric vehicles, batteries are charged when they are not being driven. This is normally accomplished through a utility connected AC-DC converter to obtain DC power from the grid. The batteries can also be charged directly from a solar resource using a DC-DC converter or from a wind source using an AC-DC converter. Energy flow is unidirectional as power is taken from the utility to charge the battery pack.

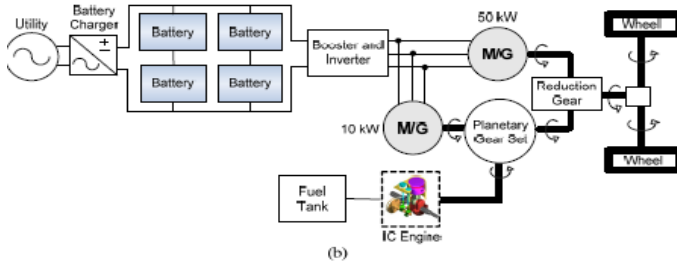

Figure 2: Configurations converted PHEV

### 3. PLUG-IN ELECTRIC VEHICLE CHARGER TOPOLOGY

The desirable characteristics for the charger are power bi-directionality (V2G and G2V), power factor equal to one, capability of performing power control, low PQ impact, construction and topology simplicity, and regular 16 A single-phase plug compatibility [6]. This charger does not allow performing fast charge, being 2.3 kW (10 A, 230 V) the advisable maximum power for a single-phase household-type plug. This power range is defined based on EU standards and power grid restrictions, since higher power ranges could represent a negative impact on the low voltage (LV) grid in terms of PQ and EMS requirements [22]–[24]. Regarding the voltage level of the battery pack, the proposed design is focused on L-category vehicles (two-, three- and four-wheel vehicles such as motorcycles, mopeds, quads, and minicars), as the one studied in [25], but could be extended to other voltage levels.

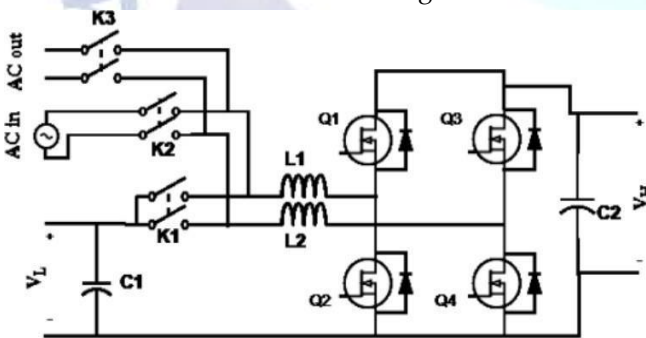

Figure 3: Proposed MMPC Topology

In MMPC this can be rectified by using an interleaved boost Power factor Correction (PFC) technique. During AC – DC operation, lower pair IGBTs can be gated to operate for PFC circuit. In MMPC, when the lower pair IGBTs are operating as boost converters, it draws continuous input current from AC mains. This input current can be controlled using average current mode control as shown in Figure 4.

Charging droplets produce a controlled amount of internal gassing. This leads to the mixing action of the battery electrolyte, keeping ready to provide a full charge.

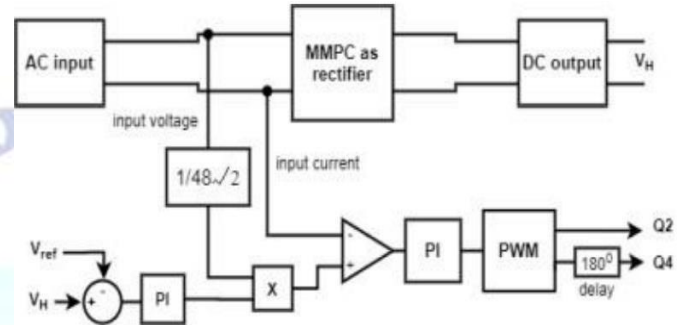

Figure 4: Average current mode control for PFC

When the harmonics comes at the input current, this control loop will operate. It has an inner loop and outer loop control. Output DC voltage sensed and provided to the outer loop. Input AC inductor current used in the inner loop made to follow the waveform of the input voltage. Output pulses from PWM provided to Q2 and Q4 with 180 phase delay

### 4. PHOTOVOLTAIC ARRAY MODELING:

In the PV network of electrical phenomenon, cell is the necessary part. For the raise in appropriate current, high power and potential difference, the sunlight dependent cells and their region unit joined in non-current or parallel fashion called as PV exhibit are used. In practical applications, each and every cell is similar to diode with the intersection designed by the semiconductor material. When the light weight is absorbed by the electrical marvel sway at the point of intersection, it gives the streams at once. The (current-voltage) and (Power-Voltage) attributes at absolutely unpredictable star intensities of the PV exhibit are represented in figure 5, whereas the often seen existence of most electrical outlet on each yield is shown in power diagram 5.

$$I = I_{ph} - I_D - I_{sh} \quad (1)$$

$$I = I_{ph} - I_0 [\exp (q V_D / nKT)] - (V_D / R_s) \quad (2)$$

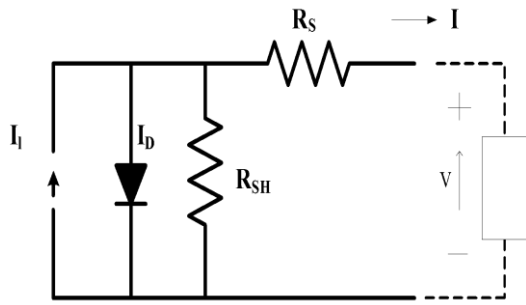

Figure 5: PV Electrical Equivalent circuit

### 5. SIMULATION DIAGRAM AND RESULT ANALYSIS FOR MMPC:

MMPC consists of four Insulated Gate Bipolar Transistors (IGBTs) with anti-parallel diodes connected as shown in Figure. Q1, Q3 constitute the upper pair and Q2, Q4 constitute lower pair IGBTs. The selection of different modes of operation can be achieved with switches denoted as K1, K2 and K3 in figure 6. VL is the low DC voltage at Auxiliary battery side and VH is the high voltage DC at the primary battery.

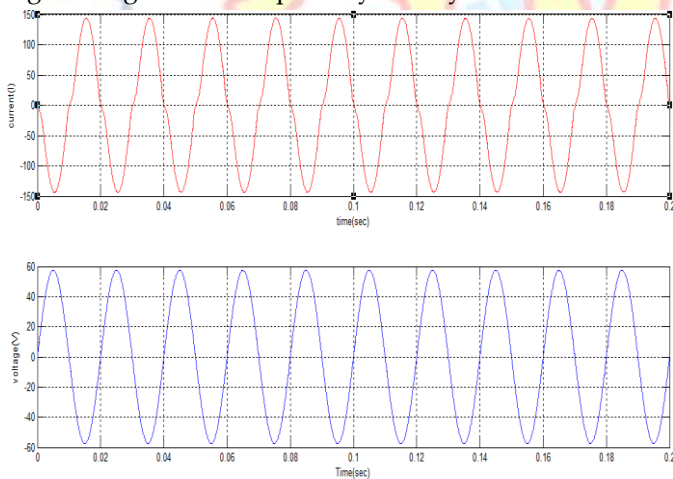

Figure 7: Input Voltage and Current Wave Forms for Ac-Dc Mode

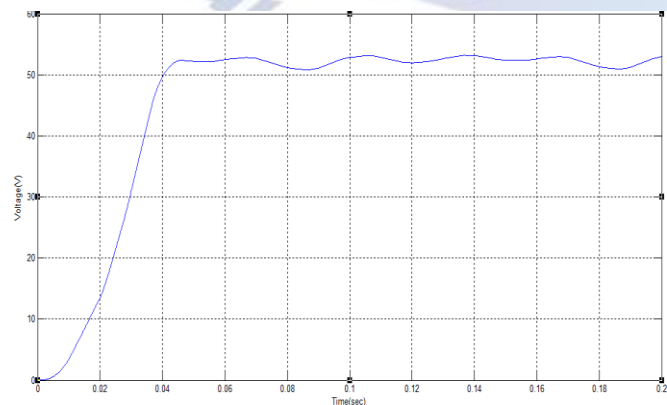

Figure 8: Output Voltage Waveform for Ac-Dc Mode

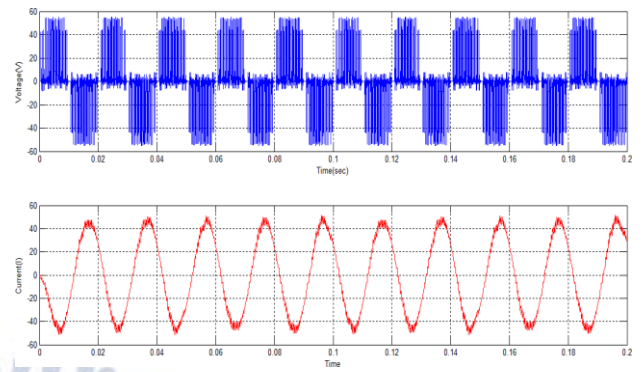

Figure 9: Output Voltage and Current Waveforms for Dc-Ac Mode

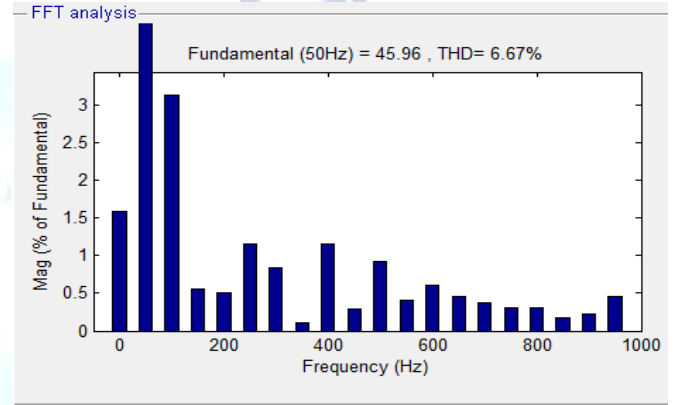

Figure 10: Thd Analysis of Output Current Waveform

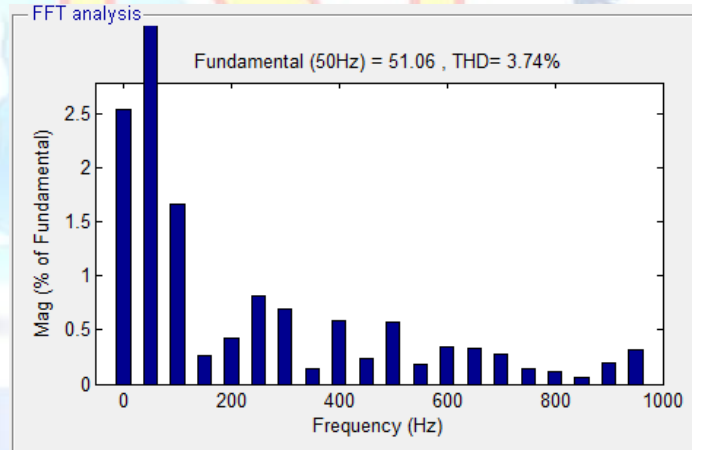

Figure 11: Thd for Output Current in Ac-Dc Mode

Table 1: RESULTS COMPARISION TABLE

S.no	MODES	PARAMETERS	PWM	Hysteresis Control
1.	AC-DC MODE	Output Voltage	54V	76V
2.	DC-AC MODE	Output Voltage	55V	62V
3.	DC-AC MODE	THD for Current	6.67%	3.74%
4.	BUCK MODE	Output Voltage	12V	26V
5.	BOOST MODE	Output Voltage	72V	140V

## 6. CONCLUSION

The fast charging stations, especially super-fast charging stations may stress power grid with potential overload at peaking time, sudden power gap and voltage sag. In this the detailed modeling of a multi port converter based EV charging station integrated with DC power generation, and battery energy storage system has been designed. The analyses of the capability for Plug-in electric vehicles (PEVs) in Vehicle to Home (V2H) scenarios, for which the vehicle acts as a residential battery storage system and/or a backup generator during a grid outage or more frequent short duration distribution system fault has been done. The simulation and experimental results show that PCMM can meet the design target and verify the feasibility of the model. This charger has been implemented using a simulation analysis with a Hysteresis Control PWM technique to validate its operation. The simulation results are obtained to see an adequate interaction between the proposed charger and a compatible autonomous EMS in a typical residential setting.

### Conflict of interest statement

Authors declare that they do not have any conflict of interest.

## REFERENCES

- [1] G. Aswani, V. S. Bhadoria, and J. Singh, "Electric Vehicles in India: Opportunities and Challenges," 2018 Int. Conf. Autom. Comput. Eng. ICACE 2018, pp. 65–71, 2018.
- [2] M. Giri and T. B. Isha, "Comparison of non-isolated schemes for EV charging and their effect on power quality," in 2017 International Conference on Circuit, Power and Computing Technologies (ICCPCT), 2017, pp. 1–7.
- [3] T. Kim and S. Kwak, "A Flexible Voltage Bus Converter for the 48-/12-V Dual Supply System in Electrified Vehicles," IEEE Trans. Veh. Technol., vol. 66, no. 3, pp. 2010–2018, 2018.
- [4] S. M. R. Tousi et al., "A digital power factor correction (PFC) control strategy optimized for DSP," IEEE Trans. Power Electron., vol. 2, no. 6, pp. 15–22, 2013.
- [5] T. Nussbaumer, K. Raggl, and J. W. Kolar, "Design guidelines for interleaved single-phase boost PFC circuits," IEEE Trans. Ind. Electron., vol. 56, no. 7, pp. 2559–2573, 2009.
- [6] S. S. Indalkar and A. Sabnis, "Comparison of AC-DC Converter Topologies Used for Battery Charging in Electric Vehicle," in 2019 2nd International Conference on Intelligent Computing, Instrumentation and Control Technologies (ICICICT), 2019, vol. 1, pp. 1624–1627.
- [7] H. S. Song, I. P. Yoo, K. Y. Jang, S. Shin, and J. H. Joo, "System for recharging plug-in hybrid vehicle and control method for the same," vol. 2, no. 12, 2010.